

# Vehicle monitoring and security system

A. Segu Hemanth Narayana<sup>1</sup>, B. Ch. Avinash<sup>1</sup> and G. Teja<sup>1</sup>

**Abstract:** The VMSS (Vehicle Monitoring and Security System) is a GPS based vehicle tracking system that is used for security applications. The project uses two main underlying concepts. These are GPS (Global Positioning System) and GSM (Global System for Mobile Communication). The main application of this system in this context is tracking the vehicle to which the GPS is connected, giving the information about its position whenever required and for the security of each person travelling by the vehicle. This is done with the help of the GPS satellite and the GPS module attached to the vehicle which needs to be tracked. The GPS antenna present in the GPS module receives the information from the GPS satellite in NMEA (National Marine Electronics Association) format and thus it reveals the position information. This information got from the GPS antenna has to be sent to the Base station wherein it is decoded. For this we use GSM module which has an antenna too. Thus we have at the Base station; the complete data about the vehicle.

## 1. INTRODUCTION

Of all the applications of GPS, Vehicle tracking and navigational systems have brought this technology to the day-to-day life of common man. Today GPS fitted cars, ambulances, fleets and police vehicles are common sights on the roads of developed countries. Known by many names such as Automatic Vehicle Locating System (AVLS), Vehicle Tracking and Information System (VTIS), Mobile Asset Management System (MAMS), these systems offer an effective tool for improving the operational efficiency and utilization of the vehicles. GPS is used in the vehicles for both tracking and navigation. Tracking systems enable a base station to keep track of the vehicles without the intervention of the driver whereas navigation system helps the driver to reach the destination. Whether navigation system or tracking system, the architecture is more or less similar. The navigation system will have convenient, usually a graphic display for the driver which is not needed for the tracking system. Vehicle tracking systems combine a number of well-developed technologies.

To design the VMSS system, we combined the GPS's ability to pin-point location along with the ability of the Global System for Mobile Communications (GSM) to communicate with a

control center in a wireless fashion. The system includes GPS-GSM modules and a base station called the control center.

Let us briefly explain how VMSS works. In order to monitor the vehicle, it is equipped with a GPS-GSM VMSS system. It receives GPS signals from satellites, computes the location information, and then sends it to the control center. With the vehicle location information, the control center displays all of the vehicle positions on an electronic map in order to easily monitor and control their routes. Besides tracking control, the control center can also maintain wireless communication with the GPS units to provide other services such as alarms, status control, and system updates.

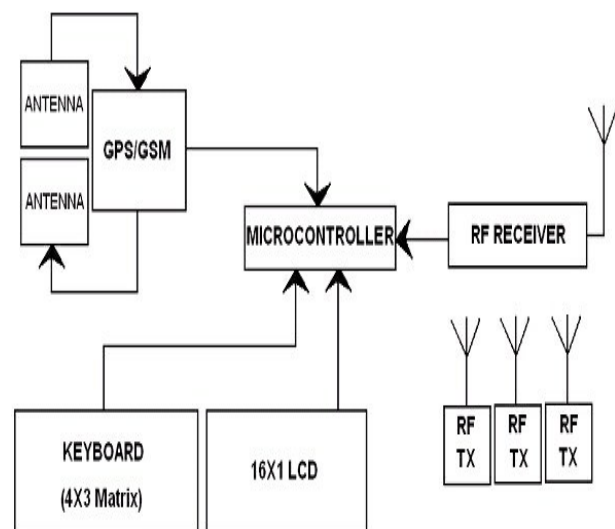

Fig 1. Vehicle monitoring system design

The design takes into consideration important factors regarding both position and data communication. Thus, the project integrates location determination (GPS) and cellular (GSM) two distinct and powerful technologies in a single system.

## 2. VEHICLE MONITORING SYSTEM DESIGN

VMSS is based on a PIC microcontroller-based system equipped with a GPS receiver and a GSM Module operating in the 900 MHz band. We housed the parts in one small plastic unit, which was then mounted on the vehicle and connected to GPS and GSM antennas (Fig. 1). The position, identity, heading, and speed are transmitted either automatically at user-defined time intervals or when a certain event occurs with an assigned message (e.g.; accident, alert, or leaving/entering an admissible geographical area).

The GPS Module outputs the vehicle location information such as longitude, latitude, direction, and Greenwich Time every five minutes. The GSM wireless communications function is based on a GSM network established in a valid region and with a valid service provider. Via the SMS provided by the GSM network, the location information and the status of the GPS-GSM VMSS are sent to the control center. Meanwhile, the VMSS receives the control information from the control center via the same SMS. Next, the GPS-GSM VMSS sends the information stored in the microcontroller via an RS-232 interface.

There are two ways to use the VMSS alarm function, which can be signified by either a buzzer or presented on LCD. The first way is to receive the command from the control center; second way is to manually send the alarm information to the control center with the push of a button. The base station consists of landline modem(s) and GIS workstation. The information about the vehicle is received at a base station and is then displayed on a PC based map. Vehicle information can be viewed on electronic maps via the Internet or specialized software. Geographic Information Systems (GIS) provides a current, spatial, visual representation of transit operations. It is a special type of computerized database management system in which geographic databases are related to one via a common set of location coordinates.

## 3. STAGES OF VEHICLE MONITORING AND SECURITY SYSTEM

### STAGE 1:

Driver starts his trip from the transport office. VMSS transmits the Driver I.D and the Vehicle I.D along with the position of the vehicle to the base station

### STAGE 2:

Taxi picks up the employee/passenger from their residence. VMSS transmits the Passenger I.D and the Vehicle I.D along with the position of the vehicle to the base station. Therefore

base station will be able to keep a track of the vehicle and thus the employee/passenger.

### STAGE 3:

Taxi drops the employee/passenger to the workplace. VMSS transmits the Passenger I.D and the Vehicle I.D along with the position of the vehicle to the base station.

### STAGE 4:

Taxi picks the employee/passenger from the workplace. VMSS transmits the Passenger I.D and the Vehicle I.D along with the position of the vehicle to the base station. Therefore this enables the base station to estimate the time if required and also keep a track of the vehicle, passenger and the driver.

### STAGE 5:

Taxi drops the employee/passenger to their residence VMSS transmits the Passenger I.D and the vehicle I.D along with the position of the vehicle to the base station and makes sure that the job is 100% complete.

## 4. CONCLUSION

In this modern, fast moving and insecure world, it is become a basic necessity to be aware of one's safety. Maximum risks occur in situations wherein an employee travels for money transactions. Also the Company to which he belongs should be aware if there is some problem. What if the person traveling can be tracked and also secured in the case of an emergency?! Fantastic, isn't? Of course it is and here's a system that functions as a tracking and a security system. It's the VMSS. This system can deal with both pace and security.