



Excellence in Higher Education
AKSHAYA
COLLEGE OF ENGINEERING AND TECHNOLOGY
(Approved by AICTE, Recognized by UGC and Affiliated to Anna University)
Accredited by NAAC - I Accredited by NBA : UG programmes of CSE, ECE & CIVIL
Kinathukadavu, Coimbatore-642109. www.acetcbce.edu.in



Department of Electronics and Communication Engineering

Technical Magazine

ACADEMIC YEAR 2024-2025 EVEN SEMESTER

Issue 2 [May, 2025]



1. Message from the Head of Department

Established in 2009, the Department of Electronics and Communication Engineering (ECE) at Akshaya College of Engineering and Technology boasts an intake of 60 students and is affiliated with Anna University. By providing high-



Mrs. K. Nimisha, AP (Sr.G)
(HoD - i/c)

quality education and maintaining excellent academic standards, the department received NBA accreditation in 2024. Offering a postgraduate programme (M.E. VLSI Design) with an intake of 9 students, the department has also been recognized as a research centre for conducting Ph.D. programmes under Anna University. With a commitment to providing professional training in emerging areas, the department aims to mould young professionals and enhance their skills and knowledge in line with current developments. Equipped with high-tech facilities, the department offers a conducive environment for students to excel in their academic pursuits and engage in research activities. Its affiliation with Anna University further enriches the academic experience, ensuring that students receive comprehensive education and training in Electronics and Communication Engineering.

2. Vision and Mission of the department

Vision

Emerge as an eminent Centre of learning in Electronics and Communication Engineering to produce engineers, capable of meeting the global challenges through design, development and research, for the welfare of the society and humanity.

Mission

DM 1: Adopt a systematic and technology enabled teaching-learning process with an ability to contribute for research.

DM 2: Develop electronics and communication engineers with managerial skills and life-long learning practices, for sustainable economic growth, beneficial to the society.

DM 3: Establish Centre of excellence in VLSI technologies and Embedded systems and provide a creative environment with industry linked initiatives for encouraging innovation.

3. Program Educational Objectives – PEOs

PEO 1: The graduates will have successful careers in industries or pursue higher studies and research or emerge as entrepreneurs.

PEO 2: The graduates will be able to apply fundamental and advanced knowledge, skills and techniques in devising innovative products for the benefits of society.

PEO 3: The graduates will be able to critically analyze existing literature in an area of specialization and research oriented methodologies to solve the problems identified.

4. Program Specific Outcomes – PSOs

PSO 1: Professional skills: Students shall have skills and knowledge to work on analog and digital systems, ad hoc and sensor networks, VLSI, embedded and communication systems

PSO 2: Competency: Students shall qualify at the State, National and International level competitive examination for employment, higher studies and research.

5. Program Outcomes –POs

PO 1: Engineering knowledge: Apply the knowledge of mathematics, science, engineering fundamentals, and an engineering specialization to the solution of complex engineering problems.

PO 2: Problem analysis: Identify, formulate, review research literature, and analyze complex engineering problems reaching substantiated conclusions using first principles of mathematics, natural sciences, and engineering sciences.

PO 3: Design/development of solutions: Design solutions for complex engineering problems and design system components or processes that meet the specified needs with appropriate consideration for the public health and safety, and the cultural, societal, and environmental considerations

PO 4: Conduct investigations of complex problems: Use research-based knowledge and research methods including design of experiments, analysis and interpretation of data, and synthesis of the information to provide valid conclusions.

PO 5: Modern tool usage: Create, select, and apply appropriate techniques, resources, and modern engineering and IT tools including prediction and modeling to complex engineering activities with an understanding of the limitations.

PO 6: The Engineer and Society: Apply reasoning informed by the contextual knowledge to assess societal, health, safety, legal and cultural issues and the consequent responsibilities relevant to the professional engineering practice.

PO 7: Environment and Sustainability: Understand the impact of the professional engineering solutions in societal and environmental contexts, and demonstrate the knowledge of, and need for sustainable development.

PO 8: Ethics: Apply ethical principles and commit to professional ethics and responsibilities and norms of the engineering practice.

PO 9: Individual and Team work: Function effectively as an individual, and as a member or leader in diverse teams, and in multidisciplinary settings.

PO 10: Communication: Communicate effectively on complex engineering activities

with the engineering community and with society at large, such as, being able to comprehend and write effective reports and design documentation, make effective presentations, and give and receive clear instructions.

PO 11: Project management and Finance: Demonstrate knowledge and understanding of the engineering and management principles and apply these to one's own work, as a member and leader in a team, to manage projects and in multidisciplinary environments.

PO 12: Life-long learning: Recognize the need for, and have the preparation and ability to engage in independent and life-long learning in the broadest context of technological change.

Message from the Editorial Team

We are excited to present to you the third issue of the ECE Department's Technical Magazine for the academic year 2024-2025(Even Semester). This edition is a reflection of the talent, dedication, and hard work of our students, showcasing their remarkable achievements in both co-curricular and extra-curricular activities.

The primary goal of this magazine is to highlight the innovative projects, research, and technical skills exhibited by our students. We believe that the exchange of knowledge and experiences plays a key role in shaping the future of technology and engineering.

We would like to extend our sincere gratitude to the Management and our esteemed Principal for their unwavering support and encouragement, which have been instrumental in the success of this initiative. We hope this magazine continues to inspire and inform, fostering a spirit of collaboration and innovation within the ECE department.

Chief Editor:	Mrs.K.Nimisha, AP (Sr.G)/ECE
Faculty Advisors:	Mrs.A.Ambika, AP (Sl.G)/ECE, Mrs.A.RamjanBegam, AP/ECE, Mr.S.Ravikumar, AP/ECE
Student Editors:	S.B.DharaniDharan, III ECE
Design Team:	Mrs.A.RamjanBegam, AP/ECE

Table of Contents

S.NO	Topics	Page No
1	INTELLIGENT SUSTAINABLE KICKS FOR THE VISUALLY IMPAIRED	10
2	EEG-CONTROLLED SMART HOME SYSTEM FOR DISABLED PEOPLE	11
3	SMART RATION INVENTORY MANAGEMENT WITH FIFO ENFORCEMENT	11
4	AI DRIVEN ULTRASOUND TECHNOLOGY FOR PREVENTING AGRICULTURAL FIELD FROM ANIMALS	12
5	SMART CHARGING CONTROLLER FOR MOBILE PHONES TO PREVENT TRICKLE CHARGING AND EXTEND BATTERY LIFE	12
6	SEWAGE WATER MONITORING AND FILTERING USING RASPBERRY PI	13
7	IOT ENABLED TIME-BASED LOAD MANAGEMENT SYSTEM	14
8	LPG TRANSPORT TRACKING AND LEAKAGE DETECTION WITH ACCIDENT PREVENTION ALERT SYSTEM	15
9	IOT BASED WAR SPYING ROBOT WITH NIGHT VISION CAMERA	15
10	DESIGNING IOT BASED FACE RECOGNITION ROBOT	16
11	VEHICLE BLACK BOX FOR ACCIDENT DETECTION AND EMERGENCY RESPONSE	17
12	IOT-BASED SMART BATTERY MANAGEMENT SYSTEM FOR REAL-TIME MONITORING AND CONTROL	18
13	INTELLIGENT EMERGENCY VEHICLE SYSTEM PRIORITY SYSTEM	19
14	ANTI FUEL THEFT DEVICE	20
15	CUSTOMIZED LORAWAN SIMULATION WITH SWIPT INTEGRATION USING NS-3	22
16	SMART WHEELCHAIR	23
17	WEARABLE AUTOMATIC ASSISTANCE GLOVE	23

18	IOT-BASED MANHOLE DETECTION AND MONITORING	24
19	VEHICLE ACCIDENT DETECTION SYSTEM	24
20	AUTOMATIC WEARABLE GLOVE ASSISTANT	25
21	VR-BASED HAND TREMOR SUPPRESSION FOR PARKINSON'S DISEASE PATIENTS	25
22	FLEXSENSE ASSISTANT	25
23	ARDUINO WEATHER STATION USING DHT11	26
24	SMART CRADLE SYSTEM	26
25	LONG-RANGE COMMUNICATION USING LORA	26
26	DESIGN OF SINGLE-BAND RECTIFIER FOR AMBIENT RF ENERGY HARVESTING	27
27	IOT-BASED SMART GARDEN WITH WEATHER STATION	27
28	EARLY WARNING SYSTEM FOR HUMAN-ELEPHANT CONFLICT	28
29	GAS LEAKAGE DETECTION SYSTEM USING GSM	28
30	LI-FI (LIGHT FIDELITY) BASED DATA TRANSMISSION	28
31	BRAIN TUMOR DETECTION SYSTEM	29
32	BATTERY MANAGEMENT SYSTEM (BMS) FOR EV CHARGING STATION	29
33	EXAM MALPRACTICE DETECTION SYSTEM	30
34	DRIVER ASSISTANCE USING SMART GLASS	30
35	EARTHQUAKE RESISTANCE BUILDING MODELS	30
36	SMART TROLLEY USING RFID – AUTOMATIC SHOPPING CART	31
37	AUTONOMOUS LINE FOLLOWER ROBOT	31
38	TOUCHLESS HAND SANITIZING SYSTEM	32
39	IOT-BASED SMART GRID SYSTEM	32
40	RFID-BASED ATTENDANCE SYSTEM	33
41	REAL-TIME SPOILAGE PREDICTION	33

INTELLIGENT SUSTAINABLE KICKS FOR THE VISUALLY IMPAIRED

Navigating urban environments presents persistent challenges for visually impaired individuals. Conventional aids like white canes and guide dogs offer only limited support in dynamic, unfamiliar settings. This paper introduces a smart, AI-enabled footwear system that assists users through adaptive obstacle detection, terrain classification, and real-time auditory feedback. Featuring travel-mode customization (Walking, Public Transport, and Long-Distance Travel), the system adapts its feedback and detection parameters according to the user's movement context. The smart shoe is built using biodegradable materials and integrates technologies such as ultrasonic sensing, GPS, AI-based vision, and a piezoelectric plate for energy harvesting and pressure-based user interaction. The piezoelectric plate not only supplies supplemental power by converting footstep pressure into electrical energy but also acts as a sensor for step detection and emergency triggers. Extensive testing validates the system's effectiveness in real-world conditions, showing promising results in accuracy, sustainability, and user satisfaction. Additionally, the system incorporates safety features such as emergency notifications, multilingual voice guidance, and environment-aware adjustments. Field tests across urban and semi-urban environments confirm the adaptability of the smart footwear to various terrains and mobility patterns. With its sustainable construction, modular hardware design, and AI-driven capabilities, the proposed system represents a scalable and inclusive solution for accessible navigation. Future directions include cloud-based learning for personalization, enhanced app integrations, and expansion into broader smart mobility ecosystems.

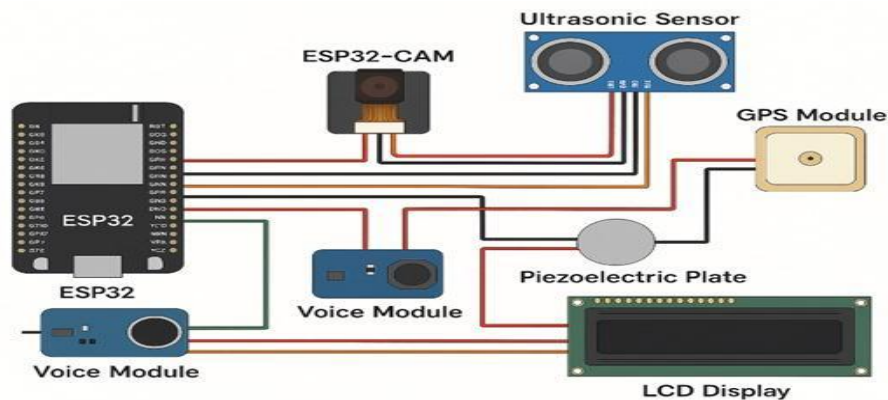

Fig 1: Electrical Design (Circuit Connections for Sensor & Feedback Systems)

**-AZHAGU DIVYA LAKSHMI.N
VISHNUDEV A D
YUVARAJ S
AMEGA S
IV ECE**

EEG-CONTROLLED SMART HOME SYSTEM FOR DISABLED PEOPLE

The work introduces the design and development of an EEG-based smart home control system to assist disabled people with improved accessibility. The system utilizes non-invasive BCI technology to facilitate hands-free control of necessary appliances at home, like lighting and air conditioners. A MindLink EEG sensor is used to identify brain activity, which calculates the degree of attention by the subject in real time. The attention data is received through Bluetooth by an HC05 module and sent to an Arduino Nano microcontroller, which translates the received signals relative to a predetermined threshold of attention. After registering an attention value higher than the threshold, the Arduino will activate a relay module to switch on the respective appliance, thus enabling users to operate devices remotely with concentrated mental effort without any physical intervention. Concurrently, the system is equipped with an ESP8266 Wi-Fi module to provide connectivity with the SinricPro cloud platform and Google Home for voice-assisted and remote controlled appliances. The two-mode control through brain signals and voice commands provides secure, flexible, and user-oriented interaction, which supports different levels of disability and context-dependent needs. The suggested solution provides a realizable, low-cost, and affordable smart home setup, providing disabled users greater independence and enhancing their well-being.

**-DENSING DEVAIRAKKAM.G
R.AZHAGUMUTHU
S.MARIAMMAL
M.PRAGATHI
IV ECE**

SMART RATION INVENTORY MANAGEMENT WITH FIFO ENFORCEMENT

This research presents a smart and automated system for managing ration stock using IoT-based technology. The system is designed to monitor inventory levels in real-time, enabling precise stock tracking, alert generation, and automatic data logging to a cloud platform. It utilizes a combination of weight sensors and RFID for identifying inventory flow and prevents manual errors common in traditional ration shops. With automated notifications for low stock and efficient cloud storage of data, the system increases transparency, reduces losses, and modernizes ration distribution processes.

Keywords— IoT, automation cloud integration, inventory control, ESP32

**-AKA TEJA KANNADAS S
NACHIAPPAN M
SANTHOSH KUMAR S
IV ECE**

AI DRIVEN ULTRASOUND TECHNOLOGY FOR PREVENTING AGRICULTURAL FIELD FROM ANIMALS

Agricultural crop loss due to animal intrusion remains a persistent challenge, particularly in regions where traditional fencing or manual monitoring proves ineffective or economically unfeasible. This paper presents an innovative AI-driven ultrasound-based system designed to prevent wild and domestic animals from entering and damaging agricultural fields. The proposed system utilizes artificial intelligence, specifically image detection through Python code, for real-time detection and classification of approaching animals using camera modules. The system processes live images and applies deep learning algorithms to identify and classify animals based on their visual profiles. Once a threat is detected, targeted ultrasonic sound frequencies—inaudible to humans but disturbing to specific animal species—are emitted to deter their entry without causing harm. The AI model is trained on a diverse dataset of animal movement patterns and visual characteristics to improve detection accuracy and minimize false positives. Additionally, the system incorporates adaptive learning capabilities to adjust ultrasonic frequencies based on the behaviour and response of the animals. This non-invasive, eco-friendly, and automated solution significantly reduces crop damage, lowers labour costs, and promotes sustainable farming practices. Field tests demonstrate a marked decrease in animal intrusions, proving the viability of AI-integrated ultrasound deterrent systems in modern agriculture.

**-ARVIND D
HARIHARAN R
RAGHUL KRISHNAN R
SIVANESAN R
IV ECE**

SMART CHARGING CONTROLLER FOR MOBILE PHONES TO PREVENT TRICKLE CHARGING AND EXTEND BATTERY LIFE

Almost every mobile phone user has faced the inconvenience of plugging their phone into the charger and then forgetting about it. Although modern smartphones are equipped with advanced charge controllers that detect when the battery is fully charged and subsequently reduce or stop the power supply trickle charging can still occur. Over time, this practice negatively impacts the battery health and shortens its lifespan, as every lithium-ion battery has a limited number of charge cycles. Additionally, temperature plays a critical role in battery degradation: prolonged charging, especially in warm conditions, can lead to overheating and accelerated wear. To address these issues, an ESP32-based smartphone charging controller can serve as a simple yet effective solution. This system allows users to set a desired charging duration, after which it automatically disconnects power to the charge using a relay controlled by the ESP32. Once the timer is activated, the relay supplies power to the

charger. When the set time expires, the ESP32 turns off the relay, effectively stopping the charging process and preventing overcharging. The main components of this setup include an ESP32 board, a relay module, a user interface for setting the timer (such as buttons or a rotary encoder), and optionally, an LCD display to show the countdown and system status. This system is designed to promote better battery health by avoiding unnecessary charging after the battery is full, reducing heat generation, and eliminating the effects of trickle charging. It is user-friendly, compact, and easily integrated into existing charging setups. In the future, the project can be enhanced with features such as temperature monitoring, current sensing to detect when the battery is fully charged automatically, wireless control through mobile apps, and even a real-time clock to schedule charging times. Overall, this ESP32-based solution provides a smart and energy-efficient way to charge smartphones while prolonging battery lifespan and ensuring safer charging practices.

**-S. SINDHU
M. SNEHA
G. SRIRAM
B. DIVYA
IV ECE**

SEWAGE WATER MONITORING AND FILTERING USING RASPBERRY PI

The increasing levels of pollution in water bodies due to the discharge of untreated sewage pose a serious threat to human health and the environment. To address this issue, the Sewage Water Monitoring and Filtering System using Raspberry Pi is proposed. This system is designed to continuously monitor the quality of sewage water using multiple sensors including pH, Turbidity, and Total Dissolved Solids (TDS).

The Raspberry Pi acts as the central processing unit that collects real-time data from the sensors and evaluates the water quality against predefined thresholds. If the water is found to be contaminated beyond acceptable limits, the system automatically triggers a filtration mechanism through a relay-controlled water pump. Additionally, the system can generate alerts via buzzer and display the water parameters on an LCD screen.

This smart and automated solution can be implemented in drainage systems, treatment plants, and industries to ensure that water being discharged or reused is safe and clean. The project contributes to sustainable water management by integrating IoT, embedded systems, and environmental engineering.

**-GUDIPATI VINOD
MADIVILI VINAYAKA
BILLA SOWMINI
ALLAM NANDINI -IV ECE**

IOT ENABLED TIME-BASED LOAD MANAGEMENT SYSTEM

The IoT Enabled Time-based Load Management System is an innovative project designed to efficiently manage power usage by integrating solar and grid power sources. This system leverages the ESP8266 microcontroller for real-time data acquisition, processing, and communication with the Blynk IoT platform, enabling remote monitoring and control. An RTC (Real-Time Clock) module is employed to ensure accurate timekeeping for load scheduling, while a Liquid Crystal Display (LCD) is used for real-time visualization of system parameters. The system continuously monitors voltage levels using an analog voltage sensor and calculates power and energy consumption by incorporating known current ratings of connected loads. Energy data is accumulated and displayed on the LCD and the Blynk app in real-time, providing users with a comprehensive view of energy usage. Two relays are utilized to switch between solar and grid power modes based on pre-defined time intervals. During solar priority hours (morning and evening), the system activates solar mode, ensuring optimal utilization of renewable energy. Outside these intervals, the system defaults to grid mode to maintain uninterrupted power supply. This dynamic switching ensures energy efficiency and reduces dependency on grid power. This project demonstrates the potential of combining IoT, renewable energy, and real-time control technologies to develop sustainable energy solutions. Its scalable design and efficient operation make it suitable for residential, commercial, and industrial applications, promoting energy conservation and cost savings. By integrating solar power with grid-based energy, the system offers a smart, adaptable, and environmentally friendly solution for modern energy management needs.

**-AJAY PRASANTH
HEMALATHA
NISHALINI
RAMUDINESH
IV ECE**

LPG TRANSPORT TRACKING AND LEAKAGE DETECTION WITH ACCIDENT PREVENTION ALERT SYSTEM

This innovative system addresses the growing need for safety in the transportation of LPG cylinders. It combines the power of embedded systems, wireless communication, and sensors to track, monitor, and respond to various emergency scenarios during LPG transport. The core of this system is the ESP32 microcontroller, which collects real-time data from sensors like the MQ2 gas sensor, fire sensor, vibration sensor, proximity sensor, and accelerometer. In case of a gas leak or an accident, the system automatically sends an SMS alert using the GSM module, along with the vehicle's GPS location. The relay and DC motor setup simulate automatic emergency vehicle response, while an LCD

displays live data to the operator. The entire hardware is compactly integrated on a PCB and powered via an external adapter. This invention aims to enhance public safety, minimize human dependency, and prevent potential disasters during LPG transportation.

**-SANGADALA BHANU PRAKASH
SALENDRA HARSHAVARDHAN
A.MATHAVAN
D.MUKESH
IV ECE**

IOT BASED WAR SPYING ROBOT WITH NIGHT VISION CAMERA

In modern military and security applications, remote surveillance and reconnaissance play a vital role in intelligence gathering. This project proposes an IoT-based war-spying robot utilizing the ESP32 microcontroller, which provides wireless connectivity via Wi-Fi and supports real-time video transmission. The robot is equipped with a night-vision camera, enabling efficient monitoring in low-light and dark environments. The ESP32 module acts as the central controller, processing movement commands and transmitting live video to a remote web interface or mobile app via a Wi-Fi server. The robot is controlled remotely, allowing operators to navigate through hazardous or enemy territory without physical presence. The system integrates DC motors, a motor driver (L298N), and ultrasonic/IR sensors for obstacle detection and autonomous navigation. In the current era of advanced warfare and border security challenges, technology plays a pivotal role in minimizing human risk while enhancing surveillance capabilities. This project presents the design and development of an IoT-based War Spying Robot integrated with a Night Vision Camera, specifically intended for military reconnaissance and intelligence-gathering operations in high-risk or inaccessible areas. The proposed system is a remote-controlled robotic vehicle equipped with a night vision camera, wireless communication modules, and obstacle avoidance sensors. It serves as an intelligent surveillance tool that transmits real-time video and sensory data to a remote command center using Internet of Things (IoT) technology. The video feed is transmitted over a wireless network (Wi-Fi, 4G LTE, or GSM) to the end user, who can monitor and control the robot's navigation using a mobile app or web dashboard. Additional features such as ultrasonic sensors for obstacle detection, GPS for location tracking, and temperature or gas sensors for environmental data collection can be integrated to further expand the robot's capabilities. These components make the robot not just a spying tool but a versatile data-gathering platform suitable for a wide range of military and security applications. The robot's compact size and rugged design enable it to navigate through narrow and uneven terrains, which is often required in border areas or urban warfare zones. By eliminating the need for soldiers to be physically present in dangerous zones, the system reduces the

risk to human life while providing continuous, real-time monitoring of enemy activity. In conclusion, the IoT-based war spying robot with a night vision camera offers a cost-effective, scalable, and secure solution for modern defense forces. It merges robotics, IoT, and image processing technologies to deliver a reliable surveillance tool that can operate effectively in challenging environments, both day and night.

**-MUTHAIYA MURALIDHARAN M
NAVEEN KUMAR P
PREM KUMAR P
SIVA P
IV ECE**

DESIGNING IOT BASED FACE RECOGNITION ROBOT

Security remains one of the most critical concerns in both residential and commercial settings. Traditional access control methods—such as physical keys, codes, or cards—are increasingly seen as insufficient in today’s digitally connected and technologically advanced world. These systems are prone to various security vulnerabilities, including theft, duplication, hacking, or simple human error. To address these issues, this project introduces a face recognition-based security system designed specifically for use in homes and office environments.

The system employs advanced computer vision techniques and machine learning algorithms to recognize authorized individuals by analyzing their facial features. This biometric approach ensures a contactless, efficient, and highly secure method of access control. Using a camera module connected to a microcontroller (e.g., Raspberry Pi), the system captures and processes images in real-time. It compares the facial features with those stored in its secured database to determine access permissions.

**-JAYASHREE.R
GOBIKAA.V
SIVARANJINI.V
SANJAY KUMAR.V
IV ECE**

VEHICLE BLACK BOX FOR ACCIDENT DETECTION AND EMERGENCY RESPONSE

The objective of this project is to develop an integrated vehicle monitoring system using the ESP32 Microcontroller, aimed at enhancing safety and efficiency for taxi owners and drivers. The system will detect accidents through a vibration sensor and accelerometer, monitor driver sobriety using an alcohol sensor and identify gas leaks using a gas sensor. The GPS module will monitor the vehicle speed and update the status to registered mobile number and also

save the details to the SD card and also in the cloud for analysis, while a telegram will send instant SMS notifications and make calls to registered mobile numbers during critical conditions. Additionally, on the LCD it displays the alert messages for critical situations and gives a buzzer signal to the driver. Camera is being added and an eye blink detection sensor whereas camera captures the set of images before an accident occurs and the eye blink sensor detects if a person doesn't blink the eyes for a particular point of threshold value, it immediately sounds the buzzer. Ultimately, this project aims to significantly improve vehicle safety, driver accountability, and operational efficiency in taxi services. The objective of this project is to develop an integrated vehicle monitoring system using the ESP32 Microcontroller, aimed at enhancing safety and efficiency for taxi owners and drivers. The system will detect accidents through a vibration sensor and accelerometer, monitor driver sobriety using an alcohol sensor and identify gas leaks using a gas sensor. The GPS module will monitor the vehicle speed and update the status to registered mobile number and also save the details to the SD card and also in the cloud for analysis, while a telegram will send instant SMS notifications and make calls to registered mobile numbers during critical conditions. Additionally, on the LCD it displays the alert messages for critical situations and gives a buzzer signal to the driver. Camera is being added and eye blink detection sensor whereas camera captures the set of images before accident occurs and the eye blink sensor detects if a person doesn't blink the eyes for a particular point of threshold iv value, it immediately sounds the buzzer. Ultimately, this project aims to significantly improve vehicle safety, driver accountability, and operational efficiency in taxi services. The objective of this project is to develop an integrated vehicle monitoring system using the ESP32 Microcontroller, aimed at enhancing safety and efficiency for taxi owners and drivers. The system will detect accidents through a vibration sensor and accelerometer, monitor driver sobriety using an alcohol sensor and identify gas leaks using a gas sensor. The GPS module will monitor the vehicle speed and update the status to registered mobile number and also save the details to the SD card and also in the cloud for analysis, while a telegram will send instant SMS notifications and make calls to registered mobile numbers during critical conditions. Additionally, on the LCD it displays the alert messages for critical situations and gives a buzzer signal to the driver. Camera is being added and an eye blink detection sensor whereas the camera captures the set of images before an accident occurs and the eye blink sensor detects if a person doesn't blink the eyes for a particular point of threshold value, it immediately sounds the buzzer. Ultimately, this project aims to significantly improve vehicle safety, driver accountability, and operational efficiency in taxi services.

**-BHAVITHIRAN V
KIRUTHIKA S
MANYA M
PRAVEEN KUMAR S
IV ECE**

IOT-BASED SMART BATTERY MANAGEMENT SYSTEM FOR REAL-TIME MONITORING AND CONTROL

This project focuses on the development and implementation of a Battery Management System (BMS) for electric vehicles, aiming to enhance battery performance, safety, and lifespan. As electric mobility becomes increasingly vital for sustainable transportation, efficient battery management is essential to address issues related to energy efficiency, thermal stability, and overall reliability. The BMS is responsible for monitoring key battery parameters such as voltage, current, and temperature, ensuring balanced charging and discharging across all cells in the battery pack.

The system architecture includes a voltage sensing unit, temperature sensing mechanisms, a current measurement setup, and a controller unit for data processing and decision-making. Protection features against overcharging, deep discharging, short-circuiting, and thermal runaway are integrated to prevent battery degradation and safety hazards. A cell balancing algorithm is employed to maintain uniform charge distribution, thereby extending battery life and improving vehicle performance.

Through simulation and modeling, the BMS is tested under various load conditions to evaluate its responsiveness and effectiveness. The project demonstrates that a well-designed BMS not only safeguards battery integrity but also contributes significantly to the efficiency and sustainability of electric vehicles. Future enhancements may involve integrating wireless communication and AI-based diagnostics for predictive maintenance and real-time optimization.

**-SARAVANAKUMAR S
DHANUNJAYA R
VINODHAGAN M
THILAK S
IV ECE**

INTELLIGENT EMERGENCY VEHICLE SYSTEM PRIORITY SYSTEM

In rapidly growing urban areas, emergency vehicles such as ambulances and fire trucks often face severe delays due to traffic congestion. This project presents an integrated system that combines IoT, deep learning, and computer vision to improve emergency response and optimize urban traffic management. At its core, the system employs an ESP32 microcontroller to dynamically control traffic signals, granting priority access to emergency vehicles. Hardware components include GPS modules for vehicle tracking, RF communication for proximity detection, and pulse rate sensors to monitor patient vitals. These

sensors transmit real-time data to the Blynk IoT platform, allowing for live monitoring and signal adjustment based on emergency presence and patient condition. On the software side, video feeds from multiple traffic lanes are analyzed using deep learning-based object detection to classify vehicle types and count their density within each lane. The system evaluates congestion levels (Low, Medium, or High) and adjusts traffic signals accordingly to streamline flow. To further enhance emergency responsiveness, an LSTM-based audio classification model is implemented to detect ambulance sirens. Trained on MFCC features, the model accurately identifies emergency sounds, triggering immediate high-priority alerts via Blynk, enabling either automatic traffic signal overrides or notifications to relevant authorities. A user-friendly Tkinter GUI supports interactive audio testing, allowing users to select, play, and classify audio files while visualizing results in real time.

**-E.ATCHAYA PRABHA
D. BALAMURUGAN
M. INDIRA
IV ECE**

ANTI FUEL THEFT DEVICE

Fuel theft is an increasingly prevalent issue that affects a broad range of sectors including transportation, logistics, agriculture, mining, and power generation. As fuel prices continue to rise globally, the incentive for criminal activities surrounding its theft grows stronger. Industries that rely heavily on fuel to power vehicles, machinery, and generators are particularly vulnerable. Unauthorized siphoning of fuel not only results in significant economic losses but also leads to operational inefficiencies, security risks, and long-term damage to organizational reputation. This pervasive problem necessitates the development and implementation of robust security systems that can actively monitor and prevent unauthorized access to fuel resources.

Traditional methods of preventing fuel theft, such as manual inspections, padlocks, and sealed caps, often fall short in effectiveness. These passive security measures can be bypassed with relative ease by individuals who possess the right tools or insider knowledge. Furthermore, these methods rely heavily on human intervention and periodic checks, which leave significant gaps in monitoring, especially in remote or unsupervised locations. In high-risk areas or large-scale operations involving fleet vehicles and fuel storage tanks, manual monitoring becomes impractical and inefficient. Consequently, there is a growing demand for automated, intelligent systems capable of offering real-time detection and response mechanisms.

In response to this need, the Anti-Fuel Theft Device introduced in this project is designed to offer a comprehensive and intelligent approach to fuel security. By combining modern electronics, embedded systems, and wireless communication technologies, this solution actively monitors fuel levels, detects

physical tampering, and prevents unauthorized fuel extraction through automated control mechanisms. The system not only alerts the user or concerned authority in the event of suspicious activity but also takes immediate preventive actions to secure the fuel supply.

At the heart of this system lies the integration of several key components, including a fuel level sensor, vibration or tamper detection module, solenoid valve, GPS tracking unit, microcontroller, and wireless communication module. These components work in tandem to form a cohesive and highly responsive security framework. The ultrasonic sensor provides continuous data on the quantity of fuel within the tank. A sudden or unexplained drop in fuel level, which exceeds a predefined threshold, is treated as a potential theft incident. Such changes trigger the system's response protocols.

. To complement the fuel level monitoring, a vibration sensor is used to detect unauthorized physical interaction with the fuel tank. Common methods of theft, such as siphoning or puncturing the tank, typically involve some level of vibration or disturbance. Upon detecting such an event, the device immediately closes the fuel line using an electromechanical solenoid valve. This mechanism acts as a secure shutoff, preventing any further loss of fuel until the system is reset by an authorized user

One of the major innovations in this device is its real-time alert system, enabled by the GPS and communication modules. Whenever an anomaly is detected—whether a drop in fuel level, tampering, or unexpected movement—the system sends immediate notifications to the user or assigned personnel. These alerts contain critical information such as the exact time and location of the event, which can be crucial for timely intervention. The GPS module also allows geofencing capabilities, wherein the system can monitor if the vehicle or fuel tank exits a predefined geographical boundary. This feature is particularly useful in preventing the unauthorized relocation of vehicles or portable tanks.

Furthermore, the inclusion of a buzzer alarm provides an additional layer of deterrence by alerting nearby individuals to the potential theft in progress. This audible warning serves to dissuade intruders and draws attention to suspicious activity. The system is designed to draw power from the vehicle or machinery's primary power supply to ensure consistent operation. To maintain functionality even during sabotage attempts or power outages, a backup battery system is integrated, ensuring that the security features remain active at all times.

The versatility of this system makes it suitable for a wide range of applications. In the transportation and logistics sector, it can be deployed across vehicle fleets to monitor fuel usage and prevent theft during transit or parking. In remote power generation sites, it helps protect generator fuel tanks from unauthorized draining. Agricultural machinery and construction equipment, often left in unmonitored areas, can also benefit from the added layer of security. This adaptability highlights the potential of the Anti-Fuel Theft Device as a scalable and reliable solution across various domains.

In conclusion, the increasing sophistication of fuel theft tactics demands equally

advanced and proactive countermeasures. The Anti-Fuel Theft Device developed in this project is a step in that direction, offering a smart, responsive, and integrated solution to fuel security challenges. By automating the detection and response process, it significantly reduces human error, improves operational oversight, and helps safeguard critical fuel assets. This system not only addresses the immediate concerns of theft prevention but also contributes to the overall efficiency and accountability of fuel management practices. With real-time alerts, automated shutdown mechanisms, and precise tracking capabilities, this device offers a powerful tool for combating fuel theft in both mobile and stationary scenarios.

**-PRADHISH S
BASKARAN R
HARISH S
IV ECE**

CUSTOMIZED LORAWAN SIMULATION WITH SWIPT INTEGRATION USING NS-3

The increasing demand for low-power, wide-area communication in the Internet of Things (IoT) has positioned LoRaWAN as a key enabler of scalable and efficient network deployments. This project presents a customized simulation framework developed using the NS-3 simulator to model a LoRaWAN-based IoT system with enhanced routing, topology, and energy management features.

The network architecture employs a structured, cluster-based topology with node-to-node communication enabled via the Ad hoc On-Demand Distance Vector (AODV) routing protocol. To reflect real-world constraints, the physical layer is tailored to Indian LoRaWAN specifications, and the simulation incorporates environmental interference, packet loss, and device-level energy modeling. A key innovation in this work is the integration of Simultaneous Wireless Information and Power Transfer (SWIPT), allowing devices to harvest energy from ambient signals during communication, significantly improving energy efficiency and sustainability.

The simulation spans a one-hour period, capturing data on transmission reliability, routing performance, and energy dynamics. Both visual (NAM-based) and trace-log outputs are used for in-depth analysis. This customized NS-3 framework serves as a robust platform for evaluating energy-aware LoRaWAN strategies and supports further research into next-generation IoT network designs optimized for power-constrained environments.

**-G.SRIDHARAN
K.SHYAM GANESH
K.KATHIRESH KUMAR
S.LOHIT
III ECE**

SMART WHEELCHAIR

This abstract presents a novel solution for physically challenged individuals, specifically those who rely on wheelchairs for mobility. The proposed solution involves the development of a Bluetooth-controlled real-time wheelchair system, which is complemented by a mobile application. The system utilizes the HC-05 Bluetooth module, an Arduino UNO microcontroller, high torque DC motors, a 20A motor driver circuit, and a 12V, 7Amp battery. The objective of this project is to enhance the mobility and independence of physically challenged individuals by providing them with an easy-to use and efficient wheelchair control mechanism. The system aims to provide enhanced control and convenience to users, enabling them to operate their wheelchairs more effectively and efficiently. The wheelchair system utilizes Bluetooth technology to establish a wireless connection between the wheelchair and a mobile device, such as a smartphone or tablet. This connection allows users to control the wheelchair's movements remotely, eliminating the need for physical contact with the wheelchair controls. The mobile application serves as the user interface, providing intuitive and customizable controls that cater to individual user needs and preferences.

**-NAGA YASHWANTH
II ECE**

WEARABLE AUTOMATIC ASSISTANCE GLOVE

This project presents a smart glove-based wearable assistance system designed for elderly and hearing-impaired individuals who face difficulty in verbal communication or mobility. The wearable glove is integrated with four soft-touch push buttons, each programmed to represent a specific request or emergency situation. With a simple press of a finger, the user can send predefined messages to a caretaker, ensuring quick assistance and enhanced independence.

Each of the four buttons on the glove corresponds to common needs like "need water," "medical help," "urgent assistance," or "food request." These inputs are detected by an Arduino microcontroller embedded in the glove, which then sends a signal using an RF transmitter module. On the caretaker's side, an RF receiver connected to another Arduino receives the signal, and the specific message is displayed on an LCD screen. At the same time, a buzzer sounds an alert to immediately grab the caretaker's attention.

The glove is designed to be lightweight, comfortable, and easy to wear, with large, easy-to-press buttons suitable even for users with reduced finger strength. The RF module allows communication without needing internet access, making the system ideal for use in both urban and rural healthcare

settings. The LCD and buzzer at the receiving end ensure that alerts are both seen and heard promptly.

This smart glove system offers a low-cost, efficient, and user-friendly wearable solution for improving communication between elderly or hearing-impaired individuals and their caregivers. It enhances personal safety, reduces response time in emergencies, and empowers users with a sense of control and dignity. The project is a valuable step toward accessible assistive technology in daily life.

**-R.VISHNUKUMAR
M.NITHISH
B.MADHAN KUMAR
M.AATHISH KUMAR
III ECE**

IOT-BASED MANHOLE DETECTION AND MONITORING

Urban safety and sanitation management are improved through an IoT-enabled manhole monitoring system. The system utilizes ultrasonic sensors to detect open or displaced covers and water level sensors to monitor drainage overflow. A NodeMCU module transmits the status data to a central monitoring server via Wi-Fi or GSM, alerting municipal authorities in real time. This automation reduces inspection workload and helps prevent accidents, especially during heavy rains. Integrated with GIS mapping tools, the system ensures precise geolocation for timely maintenance.

**-HARIVATHSAN G
LOKESHWAR S
KATHIRVEL S
MANOJ M
III ECE**

VEHICLE ACCIDENT DETECTION SYSTEM

Prompt emergency response is critical in road safety. This accident detection system employs an accelerometer and vibration sensors to identify collision events. Upon detecting an impact, the microcontroller transmits GPS coordinates to emergency services via GSM.

The system can be integrated with a vehicle's onboard diagnostics and is capable of distinguishing between minor and major impacts. This real-time alert mechanism can significantly reduce emergency response time and improve post-accident care.

**-GOKULNATH K
SURENDAR P
SRIDHAR N
SEKAR S
III ECE**

AUTOMATIC WEARABLE GLOVE ASSISTANT

Designed to support individuals with limited hand mobility, the automatic wearable glove assistant incorporates flex sensors and actuators to detect finger movement and provide powered assistance. The glove's embedded microcontroller interprets signals and adjusts tension using servo motors, helping users with grasping and releasing objects.

The glove can be customized for rehabilitation therapy or daily assistance, enhancing the quality of life for patients with neuromuscular conditions. It serves as an intersection of wearable technology, biomedical engineering, and real-time embedded systems.

**-SWETHA T
MENAGA P
MANOGNA M
SHANMUKA LAKSHMI K
III ECE**

VR-BASED HAND TREMOR SUPPRESSION FOR PARKINSON'S DISEASE PATIENTS

This VR-based system is designed to assist patients with Parkinson's Disease (PD) by mitigating hand tremors during specific activities. It integrates IMU sensors with a VR interface to detect involuntary tremors and apply real-time visual feedback suppression.

Machine learning algorithms distinguish tremors from voluntary movement, while the VR environment provides a calming, controlled workspace. This non-invasive, therapeutic tool aids in improving motor coordination and offers potential in digital rehabilitation.

**-DHARANI DHARAN SB
KATHIRAVAN KS
DHARMARAJU B
AKASH R
III ECE**

FLEXSENSE ASSISTANT

FlexSense is a gesture-based interface developed using bend sensors that recognize finger and hand movements. This system enables users to interact with digital devices or assistive tools through simple gestures.

An embedded microcontroller processes the sensor values and maps them to predefined commands. Applications include controlling appliances, navigating digital content, or serving as an input device for people with speech or motor impairments. FlexSense highlights the power of intuitive, hands-free human-machine interaction.

**-DHARUNIKA M
REEMA S
KALAIVANI C
KAVISHREE S - III ECE**

ARDUINO WEATHER STATION USING DHT11

This compact and cost-effective weather station utilizes a DHT11 sensor for temperature and humidity monitoring. Built around an Arduino microcontroller, the data is displayed locally and optionally transmitted to an IoT cloud platform.

Real-time weather information aids in agricultural, academic, and smart home applications. The design can be expanded with rainfall or wind sensors and serves as a foundational model for environmental data acquisition systems.

**-MADHUMITHA.R
MEENA. M
GOWSIKA. S
SANDHIYA DEVI. V
III ECE**

SMART CRADLE SYSTEM

Combining comfort and safety, the smart cradle system monitors infant motion and automatically rocks the cradle when activity is detected. It integrates vibration motors, a cry detection module, and health sensors to monitor the baby's well-being.

An ESP8266 microcontroller enables remote control and alerts parents through a mobile application. This automation assists caregivers, enhances infant sleep quality, and ensures responsive parenting.

**-SRI HARINI K
JAYASHREE M.L
SAKTHI K
ARCHANA T
III ECE**

LONG-RANGE COMMUNICATION USING LORA

Low-power long-range communication is a vital enabler of IoT solutions, especially in rural and industrial environments. This work implements LoRa (Long Range) wireless technology to establish a robust, energy-efficient communication link between devices separated by several kilometers.

The system includes a LoRa transmitter-receiver pair interfaced with microcontrollers, capable of transmitting environmental data or control signals with minimal latency and power consumption. Operating in sub-GHz frequencies, it ensures penetration through dense urban or remote terrain. Applications include smart agriculture, wildlife monitoring, and asset tracking, offering reliable alternatives where cellular or Wi-Fi connectivity is unavailable.

**-SANJEEV. B
MADHAN.S
SANJAY.R
HARIBALAJI. R
III ECE**

DESIGN OF SINGLE-BAND RECTIFIER FOR AMBIENT RF ENERGY HARVESTING

As the demand for battery-free electronics grows, RF energy harvesting offers a sustainable solution. This system focuses on designing a single-band rectifier circuit capable of capturing ambient radio frequency signals and converting them into usable DC power.

The rectifier, tuned to a specific frequency (e.g., Wi-Fi at 2.4 GHz), uses Schottky diodes and impedance matching techniques for optimal efficiency. When paired with antennas, it enables power delivery for low-power IoT nodes and sensors. This passive energy source paves the way for self-powered smart devices in wireless sensor networks and remote locations.

**-THULASIDHARAN
SANJAY.V
SANJEEV KUMAR.M
SIVAMANI LOKESH
III ECE**

IOT-BASED SMART GARDEN WITH WEATHER STATION

To promote sustainable agriculture and efficient gardening, this smart garden system integrates environmental sensing and automation. Sensors for soil moisture, temperature, humidity, and light are connected to an IoT-enabled microcontroller.

The data is analyzed in real time to control irrigation systems and send updates to a cloud dashboard or mobile app. A weather module forecasts upcoming conditions, aiding in agricultural planning. This intelligent system reduces water wastage and increases crop yield, making it ideal for urban gardens, greenhouses, and precision farming.

**-ANGAMUTHU V
SUHASH S
RAHULPRASATH P
SANJAI V
III ECE**

EARLY WARNING SYSTEM FOR HUMAN-ELEPHANT CONFLICT

Human-wildlife conflict is a growing issue in forest-border regions. This early warning system aims to reduce encounters between humans and elephants by using a combination of motion sensors, thermal cameras, and vibration detectors to detect elephant presence.

When movement is identified, alerts are sent via GSM or LoRa to forest officials and nearby villages. The system can be enhanced with AI-based image recognition and solar power for uninterrupted operation. This technology not only helps preserve wildlife but also safeguards human lives and livelihoods.

**-DHINESH S
ABILESH P
BALA S
P.SANTHOSH KUMAR
III ECE**

GAS LEAKAGE DETECTION SYSTEM USING GSM

Industrial and domestic safety is greatly enhanced by real-time gas monitoring. This system uses gas sensors (MQ-series) to detect hazardous gases such as LPG or methane and triggers an alert when thresholds are exceeded.

The microcontroller communicates with a GSM module to send SMS alerts to homeowners or safety personnel, ensuring swift action. Additionally, the system can activate exhaust fans or shut off valves automatically. It's a low-cost, life-saving solution for homes, labs, and factories.

**-R. KRISHNA VENI
NANABALA DILLI
P. V. L. PRASANNA
SHATAKSHI. MD
III ECE**

LI-FI (LIGHT FIDELITY) BASED DATA TRANSMISSION

Li-Fi is an emerging communication technology that uses visible light instead of radio waves for data transmission. In this setup, LEDs transmit binary data by modulating light intensity, which is detected by a photodiode on the receiver end.

This method allows high-speed, interference-free communication, especially in environments sensitive to electromagnetic interference like hospitals and aircraft cabins. The prototype demonstrates secure, short-range data exchange and represents a promising alternative or complement to Wi-Fi in next-gen wireless systems.

**-KAKARALA ROHITH KUMAR
MALIPATEL DHANUSH KUMAR REDDY
VADDE VISHNU VARDHAN
VETCHA SIDDARDHA
III ECE**

BRAIN TUMOR DETECTION SYSTEM

Medical diagnostics are advancing rapidly with the help of AI and image processing. This brain tumor detection system utilizes MRI image datasets and applies machine learning algorithms such as CNNs (Convolutional Neural Networks) for automated classification of tumor presence.

The system preprocesses images, extracts relevant features, and identifies tumor types with improved accuracy compared to traditional manual analysis. Deployed through a Python-based GUI, it assists medical professionals in early diagnosis and treatment planning. This innovation showcases the role of ECE in healthcare and biomedical applications.

**-RAJESH KUMAR
MOHAMMED HARIS
MITHUN
SANTHOSHKUMAR
III ECE**

BATTERY MANAGEMENT SYSTEM (BMS) FOR EV CHARGING STATION

With the global shift toward electric mobility, efficient energy management in charging stations becomes vital. This article focuses on a battery management system (BMS) designed to monitor and control the charging process of electric vehicles (EVs). The BMS tracks voltage, current, temperature, and state of charge (SoC) for each battery cell using a set of sensors and a microcontroller. Communication modules (CAN bus or UART) interface with the EV and the station's central system to regulate power input and prevent overcharging or overheating. The BMS also includes safety features like automatic cutoff and thermal management, ensuring long battery life and operational safety.

Integrated with IoT for remote monitoring and analytics, this system contributes to the development of reliable and intelligent EV charging infrastructure.

**-BOYA LOKESH NAIDU
CHAKALI VISHNU
SHAIK ARISH AHMED M
II ECE**

EXAM MALPRACTICE DETECTION SYSTEM

Ensuring integrity in examination environments is essential for fair assessment. This system introduces a technology-driven approach to detect and prevent malpractice during exams using surveillance and sensor integration. A camera module, sound sensor, and PIR motion sensor monitor student activity continuously.

An Arduino or Raspberry Pi processes the sensor data, detects irregular behavior (such as movement or whispers), and flags it in real-time. Alerts can be sent to invigilators via a connected display or cloud interface. The system can also log and record footage for post-exam review.

By automating the supervision process, this solution strengthens exam integrity and allows invigilators to focus more on overall conduct rather than individual monitoring.

**-G.HARI HARAN
D.KARTHIKEYAN
BANTANAHAL LAKSHMI NARASIMHA
II ECE**

DRIVER ASSISTANCE USING SMART GLASS

To enhance road safety and driver awareness, this system integrates smart glass technology with embedded electronics to provide visual alerts and driving support. The smart glass is equipped with sensors such as accelerometers, GPS modules, and obstacle detectors. These components relay data to a microcontroller that processes situational awareness and projects warnings or directions onto a heads-up display (HUD).

Additionally, the system may include voice alerts and gesture recognition to reduce driver distraction. Real-time navigation cues, drowsiness detection, and proximity alerts improve overall driving safety.

The fusion of wearable electronics and intelligent systems in this innovation demonstrates how embedded technology can revolutionize vehicular safety and assistive driving.

**-J.KISHORE PRIYADHARSHAN
V.ESAKKI MUTHU
B.ASHOK REDDY
B.KARTHIK
II ECE**

EARTHQUAKE RESISTANCE BUILDING MODELS

Structural stability is a crucial aspect of civil and architectural engineering. This work introduces scaled building models embedded with vibration sensors and damping systems to simulate and study earthquake resistance. The system uses accelerometers to measure structural response under simulated seismic conditions.

A microcontroller collects real-time vibration data and analyzes displacement and acceleration. The model integrates shock absorbers and base isolators to demonstrate how structural damage can be mitigated. A digital dashboard or display unit shows the live readings, enabling comparison between different design techniques.

Combining electronics with structural engineering, this setup aids in the education, testing, and improvement of resilient infrastructure, especially in earthquake-prone regions.

**-S.HEMAVARSHINI
DEVADHARSHINI
THANGA LAKSHMI
SUKANYA - II ECE**

SMART TROLLEY USING RFID - AUTOMATIC SHOPPING CART

Enhancing the retail experience through automation, the smart trolley system utilizes RFID technology to create a seamless and queue-free shopping environment. Each product in the store is embedded with an RFID tag, and as the customer places an item into the trolley, an onboard RFID reader scans and records it.

An Arduino controller calculates the total bill, displays it on an LCD screen, and stores the data. At checkout, the customer can instantly pay using a digital method without waiting in lines. An optional GSM or IoT interface can send purchase details to the customer's mobile device or store database.

This system reduces human error, saves time, and improves customer satisfaction, marking a shift toward intelligent retail automation and smart commerce.

**-MONALISHA
SWATHI
HARINI
KAVISRIMATHI
II ECE**

AUTONOMOUS LINE FOLLOWER ROBOT

Automation in robotics is increasingly finding application in industrial logistics and educational platforms. The autonomous line follower robot is a classic example of intelligent navigation, capable of detecting and following a path marked on the ground using infrared (IR) sensors. It is designed to move along a predefined route, making decisions at turns and junctions based on sensor inputs.

An Arduino Uno microcontroller processes signals from the IR sensor array and controls the motor driver module to steer the robot accordingly. The system is powered by DC motors and includes speed control and obstacle detection to ensure precise movement. Enhancements such as Bluetooth control or AI-based navigation can be incorporated for advanced functionality.

This autonomous system finds real-world use in warehouse management, delivery systems, and robotic competitions, offering insight into embedded control, signal processing, and intelligent path planning.

**-R.NIRANJAN
S.ANAND KUMAR
V.LOKESH
G.DHARMESH
II ECE**

TOUCHLESS HAND SANITIZING SYSTEM

In an era that prioritizes hygiene and safety, especially in public environments, the touchless hand sanitizing system presents an elegant and practical solution. Utilizing an IR proximity sensor, the system detects the presence of hands and

activates a sanitizer-dispensing pump automatically. An Arduino Nano processes the sensor's input and triggers a relay to operate the pump for a fixed interval, thereby ensuring controlled sanitizer flow. Designed for minimal contact and maximum efficiency, the system significantly reduces the risk of cross-contamination. Ideal for institutions, healthcare facilities, and commercial spaces, this automation not only encourages better hygiene practices but also reflects how embedded systems can be applied to enhance public health measures.

**-AZHAGU DIVYA LAKSHMI N
AMEGA S
IV ECE**

IOT-BASED SMART GRID SYSTEM

Power distribution and consumption are evolving rapidly with the advent of smart technologies. The IoT-based smart grid system leverages embedded electronics and wireless communication to create a real-time, responsive energy network. At its core, the system employs current and voltage sensors to monitor power usage, which is then analyzed and transmitted via a NodeMCU or ESP32 controller.

The data is uploaded to a cloud dashboard using MQTT or HTTP protocols, allowing utility providers to visualize energy consumption patterns, detect faults, and optimize load distribution. Consumers can access this data through mobile applications, enhancing energy awareness and promoting responsible usage.

This intelligent energy management model demonstrates the potential of IoT in building a sustainable, transparent, and efficient electrical grid—a foundational component of modern smart cities.

**-B.VINU UTHARAMOORTHY
S.MOHAMMED AASIK
J.VIKASH
B.VISHWA
III ECE**

RFID-BASED ATTENDANCE SYSTEM

Managing attendance efficiently has long been a challenge in both academic and professional environments. This work introduces a smart, contactless RFID-based attendance system that automates the process and ensures accuracy and accountability. Each individual is issued a unique RFID tag, which is scanned by an RFID reader upon entry. The system identifies the person through a serial number and logs the entry with the current date and time using a Real-Time Clock (RTC) module.

The microcontroller, typically an Arduino Uno, interfaces with an RC522 RFID reader and transmits the data to a central server or stores it on an SD card. For remote monitoring and real-time reporting, an ESP8266 Wi-Fi module connects

the system to a cloud-based database. This ensures seamless integration with digital record-keeping platforms.

Capable of generating reports, monitoring entry trends, and improving security, this smart attendance solution offers a significant upgrade over traditional methods and is ideal for deployment in schools, universities, and corporate offices.

**-S.LOHIT
K.SHYAM GANESH
KATHIRESHKUMAR
G.SRIDHARAN
III ECE**

REAL-TIME SPOILAGE PREDICTION

Food safety and supply chain optimization demand intelligent systems for freshness tracking. This real-time spoilage prediction system employs gas sensors (e.g., ethylene or ammonia detectors) along with temperature and humidity monitoring to analyze perishable goods' storage conditions.

An embedded microcontroller processes the sensor data and uses machine learning algorithms to predict spoilage status. Notifications are transmitted via Wi-Fi to cloud dashboards, enabling proactive actions. This smart sensing system offers potential benefits to cold-chain logistics, supermarkets, and food packaging industries by minimizing waste and preserving food quality.

**-S.B.DHARANI DHARAN
THULASIDHARAN
K.S.KATHIRAVAN
III ECE**